

LET OUR COMPANY
HELP YOU NAIL YOUR
NEXT PROJECT WITH
HIGHEST STANDARD
PACKAGING



24* 7 ONLINE
SERVICE AVAILABLE
WITHIN 1 DAYS
ENGINEER AVAILABILITY

SAMIRKA®

GET THE BEST MANUFACTURING MACHINE
AN ISO 9001 : 2015 CERTIFIED COMPANY



samirikagroup@gmail.com



Samirika Industries Offers A Complete Range Of All Material Handling Systems Which Come Fully Equipped With All The Necessary Automation.

Our Range Of Offerings Starts With Silos/hoppers, Different Types Of Slide Gates And Diverter Valves, Fully Automatic Microprocessor Based Controller Operated Automatic Weighing And Bagging Systems, And Extends To Automatic Bag Placers And Bag Pushers, Belt Conveyor Systems, Sealing Machines, Stitching Machines, Turn Tables, Online Check Weighers With Rejection Systems and Truck Loaders.



HOPPER LOADER



JUMBO BAG UNLOADER



STORAGE SILOS



BUCKET ELEVATOR



ROUND CONVEYOR



ROLLER CONVEYOR

OPTIONS :- SERVAL BAG CLOSING SYSTEM AVAILABLE

1. SEWING MACHINE | 2. HEAT SEALING MACHINE | 3. CONVEYORS

GROSS WEIGHT PACK-GW

Features

- Gross Weight Packer Has Been Design To Pack Open Mouth Bags For Granules,pulses, Grains, Free Flow Powder
- Equiped With Surge Hopper, Product Level Indicator And Completed With Heavy Duty Support Pedastal.
- Packing Size Is 5 To 50 Kg With A Capacity UpTo3Ton/hr
- Different Feeding Devices Are Available-gravity, Belt, Single Screw



NET WEIGHT PAC/COMBO PAC - NWP/CWP

Features

- Net Weight Pac/combo Pac Has Been Design To Pack Open Mouth Bags And Jumbo Bags For Granules, Pulses, Grains, Free Flow Powder.
- Equiped With Surge Hopper, Product Level Indicator And Completed With Heavy Duty Support Pedastal.
- Packing Size Is 5 To 50 Kg And Up To 1000 Kg In This Machine. Capacity - 3 Ton/ Hr To Upto 15 Ton/ Hr
- Different Feeding Devices Are Available - gravity, Belt, Single Screw



JUMBO WEIGHT PAC-JWP

Features

- Jumbo Weight Packer Has Been Design To Pack Open Mouth Bags For Granules,pulses, Grains, Free Flow Powder
- Equiped With Surge Hopper, Product Level Indicator And Completed With Heavy Duty Support Pedastal.
- Packing Size Is 250 Kg To 1000 Kg In This Machine.
- Capacity - 12 Bags/hr
- Different Feeding Devices Are Available - Gravity, Belt, Single Screw



OTHER PRODUCTS

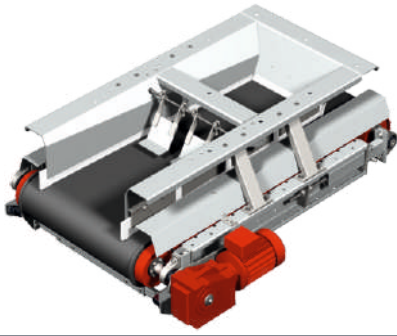

BELT FEEDER



BAG TURNER



PNEUMATIC SLIDEGATE

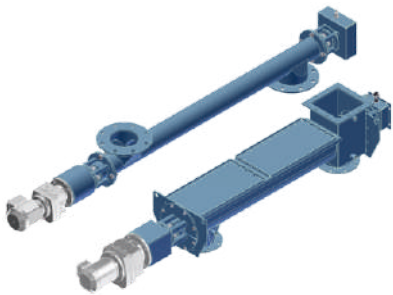

SCREW CONVEYOR



NET WEIGH HEAD

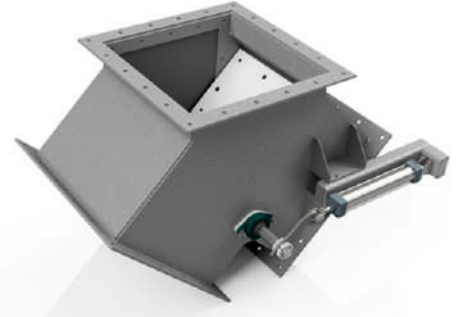

DIVERTER VALVE

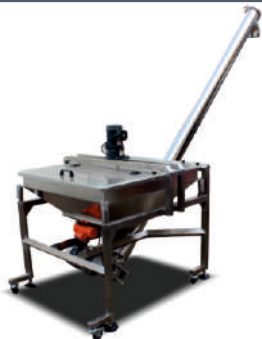

SCREW FEEDER



STITCHING MACHINE

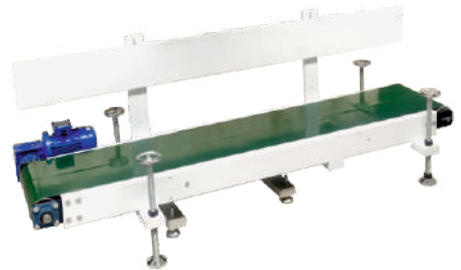

BELT CONVEYOR

Get in touch now



📍 47, Paavan Industrial Park, opp. Shreenathji Ind Estate,
Bakrol - Bujrang, Ahmedabad, Gujarat- 382430

☎ +91 98242 02545 / +91 99093 63053 / +91 75676 13811

✉ samirikagroup@gmail.com

🌐 www.samirikagroup.in